



AiP74HC/HCT47 BCD-to-Seven-Segment Common anode LED Decodes/Drivers

Product Specification

Specification Revision History:

Version	Date	Description
2012-06-A1	2012-06	New
2023-04-B1	2023-04	Update the template
2023-06-B2	2023-06	Revise the content



Contents

1、 General Description.....	3
2、 Block Diagram And Pin Description	6
2.1、 Block Diagram	6
2.2、 Pin Configurations.....	6
2.3、 Pin Description	7
2.4、 Function Table.....	7
3、 Electrical Parameter	8
3.1、 Absolute Maximum Ratings.....	8
3.2、 Recommended Operating Conditions	9
3.3、 Electrical Characteristics	9
3.3.1、 DC Characteristics 1	9
3.3.2、 DC Characteristics 2	10
3.3.3、 AC Characteristics	11
4、 Testing Circuit	12
4.1、 AC Testing Circuit	12
4.2、 Test Data	12
4.3、 AC Testing Waveforms.....	12
4.4、 Measurement Points	12
5、 Package Information	13
5.1、 DIP16	13
5.2、 SOP16	14
5.3、 TSSOP16.....	15
6、 Statements And Notes	16
6.1、 The name and content of Hazardous substances or Elements in the product	16
6.2、 Notes	16



1、 General Description

The AiP74HC/HCT47 feature active-low outputs designed for driving common-anode LEDs or incandescent indicators directly. Display patterns for BCD input counts above 9 are unique symbols to authenticate input conditions.

Features:

- Supply voltage range:
AiP74HC47: 2V to 6V
AiP74HCT47: 4.5V to 5.5V
- Input levels:
AiP74HC47: CMOS level
AiP74HCT47: TTL level
- Temperature range: -40°C to +125°C
- Packaging information: DIP16/SOP16/TSSOP16

**Ordering Information:****Tube packing specifications:**

Part number	Packaging form	Marking code	Tube quantity	Boxed tube quantity	Boxed quantity	Notes
AiP74HC47DA16.TB	DIP16	74HC47	25 PCS/tube	40 tube/box	1000 PCS/box	Dimensions of plastic enclosure: 19.0mm×6.4mm Pin spacing: 2.54mm
AiP74HCT47DA16.TB	DIP16	74HCT47	25 PCS/tube	40 tube/box	1000 PCS/box	Dimensions of plastic enclosure: 19.0mm×6.4mm Pin spacing: 2.54mm
AiP74HC47SA16.TB	SOP16	74HC47	50 PCS/tube	200 tube/box	10000 PCS/box	Dimensions of plastic enclosure: 10.0mm×3.9mm Pin spacing: 1.27mm
AiP74HCT47SA16.TB	SOP16	74HCT47	50 PCS/tube	200 tube/box	10000 PCS/box	Dimensions of plastic enclosure: 10.0mm×3.9mm Pin spacing: 1.27mm
AiP74HC47TA16.TB	TSSOP16	74HC47	96 PCS/tube	200 tube/box	19200 PCS/box	Dimensions of plastic enclosure: 5.0mm×4.4mm Pin spacing: 0.65mm
AiP74HCT47TA16.TB	TSSOP16	74HCT47	96 PCS/tube	200 tube/box	19200 PCS/box	Dimensions of plastic enclosure: 5.0mm×4.4mm Pin spacing: 0.65mm



Reel packing specifications:

Part number	Packaging form	Marking code	Reel quantity	Boxed reel quantity	Notes
AiP74HC47SA16.TR	SOP16	74HC47	4000 PCS/reel	8000 PCS/box	Dimensions of plastic enclosure: 10.0mm×3.9mm Pin spacing:1.27mm
AiP74HCT47SA16.TR	SOP16	74HCT47	4000 PCS/reel	8000 PCS/box	Dimensions of plastic enclosure: 10.0mm×3.9mm Pin spacing:1.27mm
AiP74HC47TA16.TR	TSSOP16	74HC47	5000 PCS/reel	10000 PCS/box	Dimensions of plastic enclosure: 5.0mm×4.4mm Pin spacing:0.65mm
AiP74HCT47TA16.TR	TSSOP16	74HCT47	5000 PCS/reel	10000 PCS/box	Dimensions of plastic enclosure: 5.0mm×4.4mm Pin spacing:0.65mm

Note: If the physical information is inconsistent with the ordering information, please refer to the actual product.



2、Block Diagram And Pin Description

2.1、Block Diagram

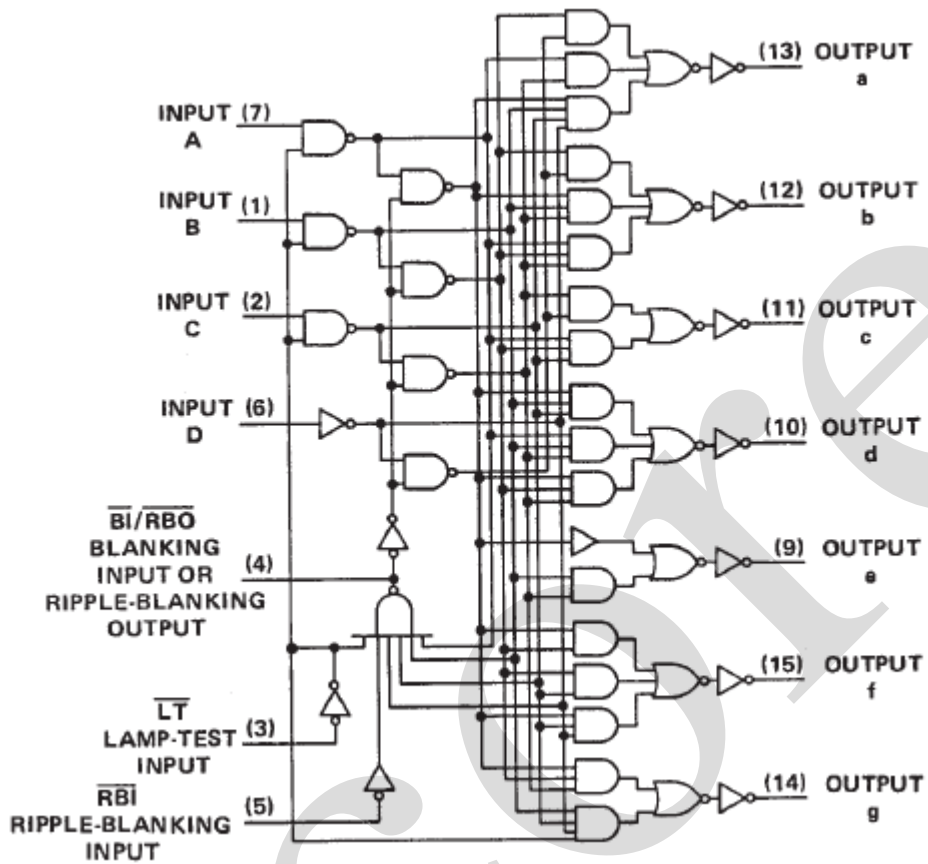
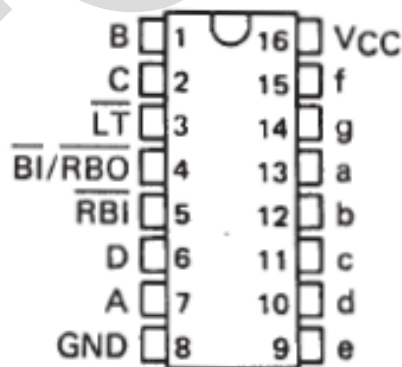

Figure 1. Logic symbol

2.2、Pin Configurations





2.3、Pin Description

Pin No.	Pin Name	Description
1	B	data input
2	C	data input
3	$\overline{\text{LT}}$	lamp test
4	$\overline{\text{BI/RBO}}$	blanking input/ripple blanking output
5	$\overline{\text{RBI}}$	ripple blanking input
6	D	data input
7	A	data input
8	GND	ground (0V)
9	e	data output
10	d	data output
11	c	data output
12	b	data output
13	a	data output
14	g	data output
15	f	data output
16	V _{CC}	supply voltage

2.4、Function Table

Decimal or function	Input						$\overline{\text{BI/RBO}}$	Output						
	$\overline{\text{LT}}$	$\overline{\text{RBI}}$	D	C	B	A		a	b	c	d	e	f	g
0	H	H	L	L	L	L	H	on	on	on	on	on	on	off
1	H	X	L	L	L	H	H	off	on	on	off	off	off	off
2	H	X	L	L	H	L	H	on	on	off	on	on	off	on
3	H	X	L	L	H	H	H	on	on	on	on	off	off	on
4	H	X	L	H	L	L	H	off	on	on	off	off	on	on
5	H	X	L	H	L	H	H	on	off	on	on	off	on	on
6	H	X	L	H	H	L	H	off	off	on	on	on	on	on
7	H	X	L	H	H	H	H	on	on	on	off	off	off	off
8	H	X	H	L	L	L	H	on	on	on	on	on	on	on
9	H	X	H	L	L	H	H	on	on	on	off	off	on	on
10	H	X	H	L	H	L	H	off	off	off	on	on	off	on
11	H	X	H	L	H	H	H	off	off	on	on	off	off	on
12	H	X	H	H	L	L	H	off	on	off	off	off	on	on
13	H	X	H	H	L	H	H	on	off	off	on	off	on	on
14	H	X	H	H	H	L	H	off	off	off	on	on	on	on
15	H	X	H	H	H	H	H	off	off	off	off	off	off	off
$\overline{\text{BI}}$	X	X	X	X	X	X	L	off	off	off	off	off	off	off
$\overline{\text{RBI}}$	H	L	L	L	L	L	L	off	off	off	off	off	off	off
$\overline{\text{LT}}$	L	X	X	X	X	X	H	on	on	on	on	on	on	on

Note:



[1] H=HIGH voltage level; L=LOW voltage level; X=don't care.

[2] The blanking input ($\overline{\text{BI}}$) must be open or held at a high logic level when output functions 0 through 15 are desired. The ripple-blanking input ($\overline{\text{RBI}}$) must be open or high if blanking of a decimal zero is not desired.

[3] When a low logic level is applied directly to the blanking input ($\overline{\text{BI}}$), all segment outputs are off regardless of the level of any other input.

[4] When ripple-blanking input ($\overline{\text{RBI}}$) and inputs A, B, C, D are at a low level with the lamp test input high, all segment outputs go off and the ripple-blanking output ($\overline{\text{RBO}}$) goes to a low level (response condition).

[5] When the blanking input/ripple blanking output ($\overline{\text{BI}}/\overline{\text{RBO}}$) is open or held high and a low is applied to the lamp test input, all segment outputs are on.

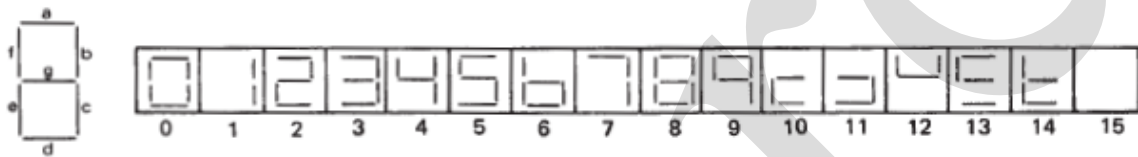

Figure 3. Segment identification

3、Electrical Parameter

3.1、Absolute Maximum Ratings

(Voltages are referenced to GND (ground=0V), unless otherwise specified.)

Parameter	Symbol	Conditions	Min.	Max.	Unit
supply voltage	V_{CC}	-	-0.5	+7	V
supply current	I_{CC}	-	-	50	mA
ground current	I_{GND}	-	-50	-	mA
input clamping current	I_{IK}	$V_I < -0.5V$ or $V_I > V_{CC}+0.5V$	-	± 20	mA
output clamping current	I_{OK}	$V_O < -0.5V$ or $V_O > V_{CC}+0.5V$	-	± 20	mA
output current	I_O	$-0.5V < V_O < V_{CC}+0.5V$	-	± 25	mA
storage temperature	T_{stg}	-	-65	+150	$^{\circ}\text{C}$
soldering temperature	T_L	10s	DIP	245	$^{\circ}\text{C}$
			SOP/TSSOP	260	



3.2、Recommended Operating Conditions

Parameter	Symbol	Conditions	Min.	Typ.	Max.	Unit
AiP74HC47						
supply voltage	V_{CC}	-	2.0	5.0	6.0	V
input voltage	V_I	-	0	-	V_{CC}	V
output voltage	V_O	-	0	-	V_{CC}	V
ambient temperature	T_{amb}	-	-40	-	+125	°C
AiP74HCT47						
supply voltage	V_{CC}	-	4.5	5.0	5.5	V
input voltage	V_I	-	0	-	V_{CC}	V
output voltage	V_O	-	0	-	V_{CC}	V
ambient temperature	T_{amb}	-	-40	-	+125	°C

3.3、Electrical Characteristics

3.3.1、DC Characteristics 1

($T_{amb}=-40^{\circ}\text{C}$ to $+85^{\circ}\text{C}$, voltages are referenced to GND (ground=0V), unless otherwise specified.)

Parameter	Symbol	V_{CC}	Conditions	Min.	Typ.	Max.	Unit
AiP74HC47							
HIGH-level input voltage	V_{IH}	2.0V	-	1.5	1.2	-	V
		4.5V	-	3.15	2.4	-	V
		6.0V	-	4.2	3.2	-	V
LOW-level input voltage	V_{IL}	2.0V	-	-	0.8	0.5	V
		4.5V	-	-	2.1	1.35	V
		6.0V	-	-	2.8	1.8	V
LOW-level output voltage	V_{OL}	2.0V	$I_O=20\mu\text{A}$	-	0	0.1	V
		4.5V	$I_O=20\mu\text{A}$	-	0	0.1	V
		6.0V	$I_O=20\mu\text{A}$	-	0	0.1	V
		4.5V	$I_O=4.0\text{mA}$	-	0.15	0.33	V
		6.0V	$I_O=5.2\text{mA}$	-	0.16	0.33	V
HIGH-level input current	I_{IH}	6.0V	$V_I=V_{CC}$	-	-	20	μA
LOW-level input current	$I_{IL(A/B/C/D)}$	6.0V	$V_I= \text{GND}$	-	-	-20	μA
	$I_{IL(BI/RBO/RBI/LT)}$	6.0V	$V_I= \text{GND}$	-	-	-1.2	mA
supply current	I_{CC}	6.0V	$V_I=V_{CC}$ or $\text{GND}; I_O=0\text{A}$	-	-	13	mA
AiP74HCT47							
HIGH-level input voltage	V_{IH}	4.5V to 5.5V	-	2.0	1.6	-	V
LOW-level input voltage	V_{IL}	4.5V to 5.5V	-	-	1.2	0.8	V
LOW-level output voltage	V_{OL}	4.5V	$I_O=20\mu\text{A}$	-	0	0.1	V
			$I_O=4.0\text{mA}$	-	0.16	0.26	V
HIGH-level input current	I_{IH}	6.0V	$V_I=V_{CC}$	-	-	20	μA



LOW-level input current	$I_{IL}(A/B/C/D)$	6.0V	$V_I = GND$	-	-	-20	μA
	$I_{IL}(BI/RBO/RBI/LT)$	6.0V	$V_I = GND$	-	-	-1.2	mA
supply current	I_{CC}	6.0V	$V_I = V_{CC}$ or GND; $I_O = 0A$	-	-	13	mA
additional supply current	ΔI_{CC}	4.5V to 5.5V	One input at $V_I = V_{CC} - 2.1V$; Other inputs at V_{CC} or GND; $I_O = 0A$	-	-	500	μA

3.3.2、DC Characteristics 2

($T_{amb} = -40^{\circ}C$ to $+125^{\circ}C$, voltages are referenced to GND (ground=0V), unless otherwise specified.)

Parameter	Symbol	V_{CC}	Conditions	Min.	Typ.	Max.	Unit
AiP74HC47							
HIGH-level input voltage	V_{IH}	2.0V	-	1.5	-	-	V
		4.5V	-	3.15	-	-	V
		6.0V	-	4.2	-	-	V
LOW-level input voltage	V_{IL}	2.0V	-	-	-	0.5	V
		4.5V	-	-	-	1.35	V
		6.0V	-	-	-	1.8	V
LOW-level output voltage	V_{OL}	2.0V	$I_O = 20\mu A$	-	-	0.1	V
		4.5V	$I_O = 20\mu A$	-	-	0.1	V
		6.0V	$I_O = 20\mu A$	-	-	0.1	V
		4.5V	$I_O = 4.0mA$	-	-	0.4	V
		6.0V	$I_O = 5.2mA$	-	-	0.4	V
HIGH-level input current	I_{IH}	6.0V	$V_I = V_{CC}$	-	-	20	μA
LOW-level input current	$I_{IL}(A/B/C/D)$	6.0V	$V_I = GND$	-	-	-20	μA
	$I_{IL}(BI/RBO/RBI/LT)$	6.0V	$V_I = GND$	-	-	-1.2	mA
supply current	I_{CC}	6.0V	$V_I = V_{CC}$ or GND; $I_O = 0A$	-	-	13	mA
AiP74HCT47							
HIGH-level input voltage	V_{IH}	4.5V to 5.5V	-	2.0	-	-	V
LOW-level input voltage	V_{IL}	4.5V to 5.5V	-	-	-	0.8	V
LOW-level output voltage	V_{OL}	4.5V	$I_O = 20\mu A$	-	-	0.1	V
			$I_O = 4.0mA$	-	-	0.4	V
HIGH-level input current	I_{IH}	6.0V	$V_I = V_{CC}$	-	-	20	μA
LOW-level input current	$I_{IL}(A/B/C/D)$	6.0V	$V_I = GND$	-	-	-20	μA
	$I_{IL}(BI/RBO/RBI/LT)$	6.0V	$V_I = GND$	-	-	-1.2	mA



supply current	I_{CC}	6.0V	$V_I=V_{CC}$ or GND; $I_O=0A$	-	-	13	mA
additional supply current	ΔI_{CC}	4.5V to 5.5V	One input at $V_I=V_{CC}-2.1V$; Other inputs at V_{CC} or GND; $I_O=0A$	-	-	500	μA

3.3.3、 AC Characteristics

($T_{amb}=25^{\circ}C$, voltages are referenced to GND (ground=0V), unless otherwise specified.)

Parameter	Symbol	Conditions	Min.	Typ.	Max.	Unit	
AiP74HC47							
Turn-on time	t_{ON}	$V_{CC}=5.0V$; $C_L=15pF$; $R_L=665\Omega$	from A input	-	-	100	ns
			from \bar{RBI} input, outputs (a-f only)	-	-	100	ns
Turn-off time	t_{OFF}	$V_{CC}=5.0V$; $C_L=15pF$; $R_L=665\Omega$	from A input	-	-	100	ns
			from \bar{RBI} input, outputs (a-f only)	-	-	100	ns
AiP74HCT47							
Turn-on time	t_{ON}	$V_{CC}=5.0V$; $C_L=15pF$; $R_L=665\Omega$	from A input	-	-	100	ns
			from \bar{RBI} input, outputs (a-f only)	-	-	100	ns
Turn-off time	t_{OFF}	$V_{CC}=5.0V$; $C_L=15pF$; $R_L=665\Omega$	from A input	-	-	100	ns
			from \bar{RBI} input, outputs (a-f only)	-	-	100	ns



4、Testing Circuit

4.1、AC Testing Circuit

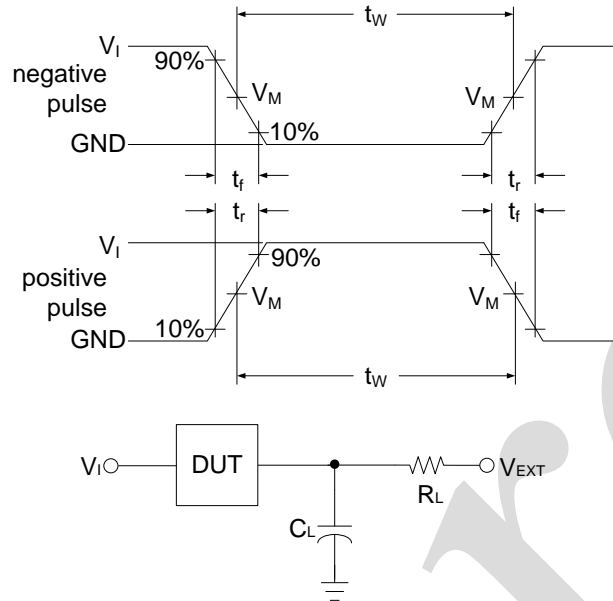

Figure 4. Test circuit for measuring switching times

C_L includes probe and jig capacitance.

4.2、Test Data

Type	Input		Load		V_{EXT}
	V_I	$t_r = t_f$	C_L	R_L	t_{ON}/t_{OFF}
AiP74HC47	V_{CC}	3.0ns	15pF	665Ω	V_{CC}
AiP74HCT47	3.0V	3.0ns	15pF	665Ω	V_{CC}

4.3、AC Testing Waveforms

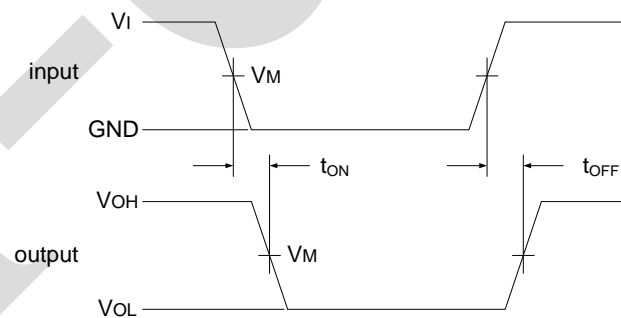

4.4、Measurement Points

Type	Input	Output
	V_M	V_M
AiP74HC47	$0.5 \times V_{CC}$	$0.5 \times V_{CC}$
AiP74HCT47	1.3V	1.3V



5、 Package Information

5.1、 DIP16

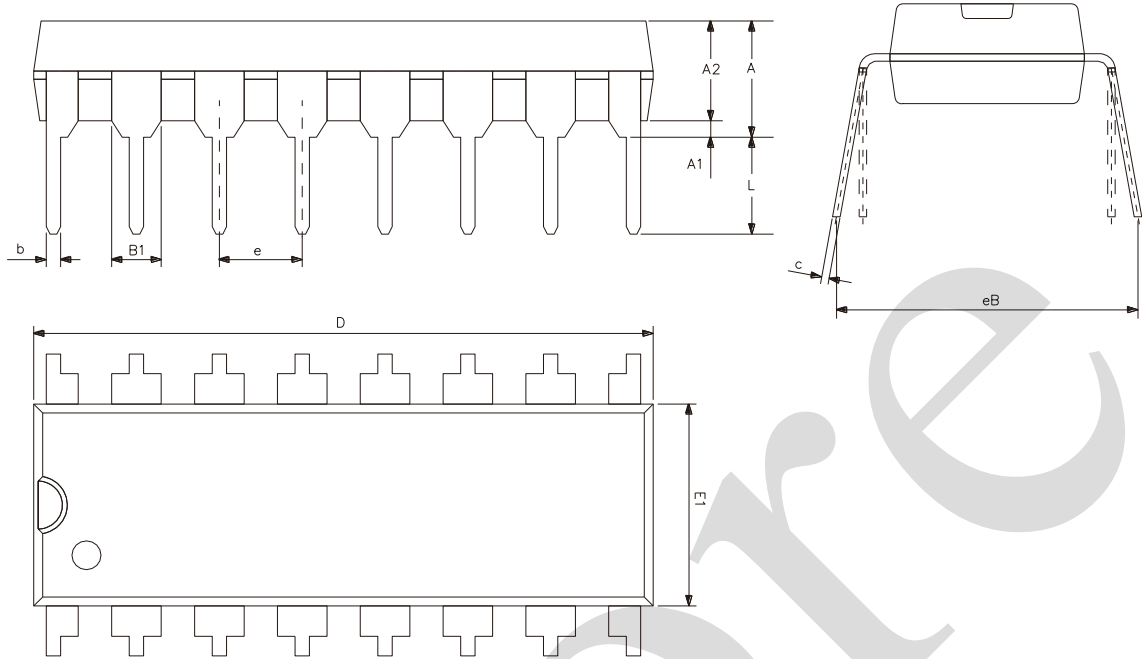

Symbol	Dimensions (mm)	
	Min.	Max.
A2	3.20	3.60
A1	0.51	-
A	3.60	5.33
L	3.00	3.60
b	0.36	0.56
B1	1.52	
D	18.80	19.94
E1	6.20	6.60
e	2.54	
c	0.20	0.36
eB	7.62	9.30



5.2、SOP16

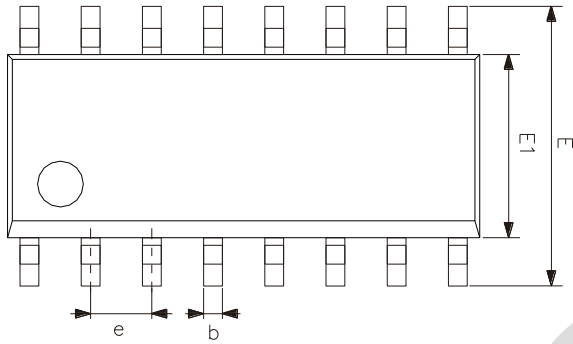
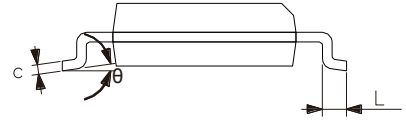
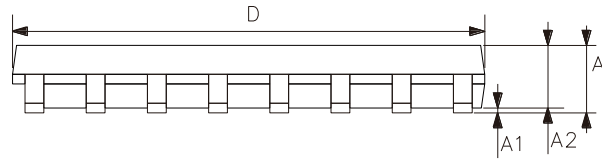

Symbol	Dimensions (mm)	
	Min.	Max.
A	1.35	1.80
A1	0.10	0.25
A2	1.25	1.55
b	0.33	0.51
c	0.19	0.25
D	9.50	10.10
E	5.80	6.30
E1	3.70	4.10
e	1.27	
L	0.35	0.89
θ	0°	8°



5.3、TSSOP16

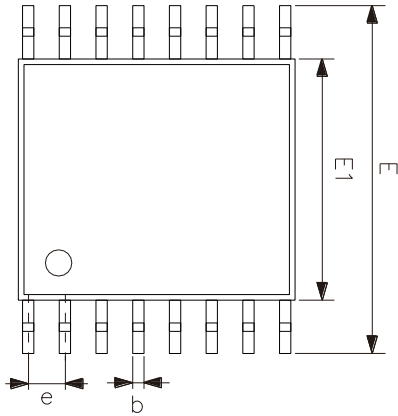
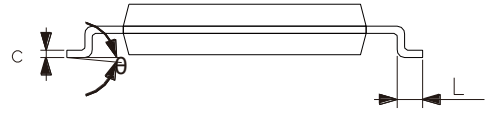
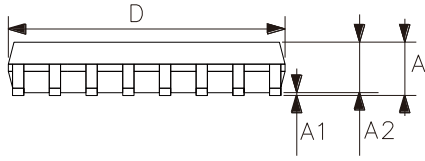

Symbol	Dimensions (mm)	
	Min.	Max.
A	-	1.20
A1	0.05	0.15
A2	0.80	1.05
b	0.19	0.30
c	0.09	0.20
D	4.90	5.10
E1	4.30	4.50
E	6.20	6.60
e	0.65	
L	0.45	0.75
θ	0°	8°



6、 Statements And Notes

6.1、 The name and content of Hazardous substances or Elements in the product

Part name	Hazardous substances or Elements									
	Lead and lead compounds	Mercury and mercury compounds	Cadmium and cadmium compounds	Hexavalent chromium compounds	Polybrominated biphenyls	Polybrominated biphenyl ethers	Dibutyl phthalate	Butylbenzyl phthalate	Di-2-ethylhexyl phthalate	Diisobutyl phthalate
Lead frame	○	○	○	○	○	○	○	○	○	○
Plastic resin	○	○	○	○	○	○	○	○	○	○
Chip	○	○	○	○	○	○	○	○	○	○
The lead	○	○	○	○	○	○	○	○	○	○
Plastic sheet installed	○	○	○	○	○	○	○	○	○	○
explanation	○: Indicates that the content of hazardous substances or elements in the detection limit of the following the SJ/T11363-2006 standard. ×: Indicates that the content of hazardous substances or elements exceeding the SJ/T11363-2006 Standard limit requirements.									

6.2、 Notes

We recommend you to read this chapter carefully before using this product.

The information in this chapter is provided for reference only and i-Core disclaims any express or implied warranties, including but not limited to applicability, special application or non-infringement of third party rights.

This product is not suitable for critical equipment such as life-saving, life-sustaining or safety equipment. It is also not suitable for applications that may result in personal injury, death, or serious property or environmental damage due to product malfunction or failure. I-Core will not be liable for any damages incurred by the customers at their own risk for such applications.

The customer is responsible for conducting all necessary tests i-Core's application to avoid failure in the application or the application of the customer's third party users. I-Core does not accept any liability.

The Company reserves the right to change or improve the information published in this chapter at any time.

The information in this chapter are subject to change without notice. We recommend the customer to consult our sales staff before purchasing.

Please obtain related materials form i-Core's regular channels and we are not responsible for its content if it is provided by sources other than our company.

In case of any conflict between the Chinese and English version, the version is subject to the Chinese one.